



DUKERS

Quality Commercial Refrigeration



BACK BAR COOLER

MODEL DBB48-H2
Swinging Glass Door



TECHNICAL SPECIFICATIONS

Voltage/Frequency	115V/60Hz
Refrigerant	R290
Type of Defrost	Automatic
Interior Material	Stainless Steel
Exterior Material	Black Textured Finish
Temperature Range °F	33 ~ 38°F
Compressor Power (HP)	1/3
Nema Config.	NEMA5-15P



PRODUCT FEATURES

- The side mount compressor structure is placed in an easy access area, provides quick and convenient access.
- R290 Natural Refrigerant promotes faster cool down and efficient energy consumption.
- Precision digital temperature controls allow pinpoint accuracy with temperatures from 33-38°F.
- Stainless steel top, sealed interior floors, and rounded cabinet corners for easy cleaning.
- Adjustable, heavy-duty epoxy coated shelves.
- Constructed of commercial-grade body panels in black textured finish to fit all decors and living spaces.
- Featured in a large size and double pane tempered glass block UV light to safely keep all types of drinks ready to serve.
- LED interior lighting for bright product display.
- Optional casters with breaks available upon request for better cleaning and mobility.



HEAVY-DUTY CABINET FRAME & ROBUST DESIGN



DUKERS

Los Angeles | San Francisco | Dallas
Houston | Florida | Chicago | New Jersey

1-800-931-8628

@ info@dukersusa.com

www.DukersUSA.com

DETAILS & SPECIFICATIONS

BACK BAR COOLER

Front View

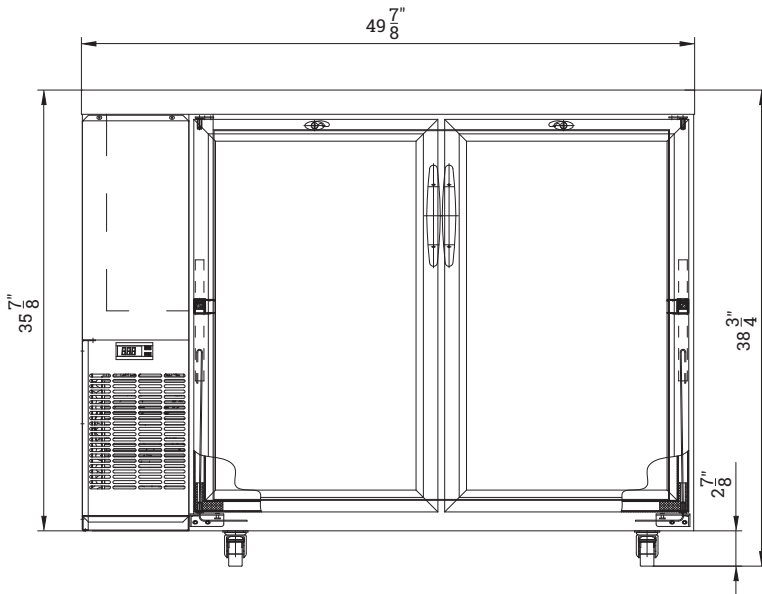

Side View

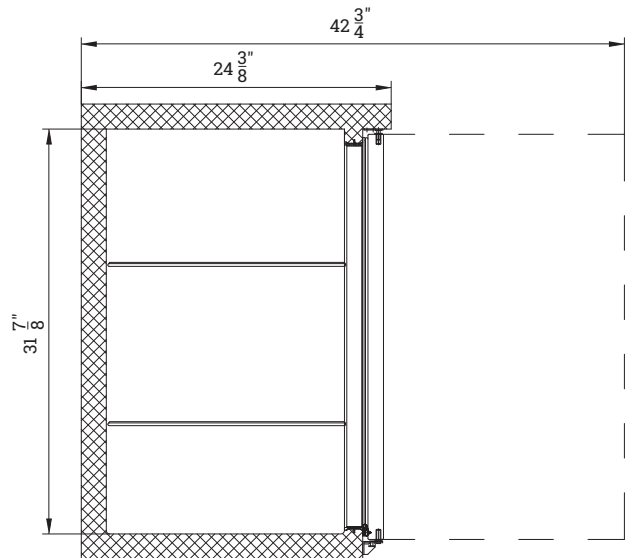

MODEL DBB48-H2

Rated Voltage	115V
Rated Frequency	60Hz
Total Input Power	284W
Total Current	2.66A
Total Capacity	11.23 cu ft
Climatic Category	4-5
Protection Type	I
Design Pressure High Side	385 PSIG
Design Pressure Low Side	150 PSIG
Insulation Blowing Gas	C-Pentane
Refrigerant	R290/3.17 oz



115/60/1
NEMA-5-15P



MODEL	EXTERNAL DIMENSION WXDXH (INCHES)	PACKAGING DIMENSION WXDXH (INCHES)	PRODUCT NET WEIGHT	# OF SHELVES	40FT (PCS)
DBB48-H2	49 7/8"x24 3/4"x38 3/4"	51 5/8"x26 3/8"x43 1/4"	198 lbs	4	54



Los Angeles | San Francisco | Dallas
Houston | Florida | Chicago | New Jersey

1-800-931-8628

@ info@dukersusa.com

www.DukersUSA.com